

Uniblitz® CS25

25mm Uni-Stable Optical Shutter



Overview

The Uniblitz CS25 has been designed to provide accurate, repeatable exposures for a wide variety of applications including microscopy, video imaging, and more. The slim form-factor provides a 25mm aperture that can be inserted into a 2.37 inch diameter housing. The CS25 is available in a housed or an un-housed configuration for OEM applications (or simply where spatial limitations are a consideration).

Uni-stable shutter devices, like the CS25, require power to hold the blades in the open state.

Need Support? Please [visit our website](#) or email us at info@uniblitz.com.

Tel: 585-385-5930 | Toll-Free: 800-828-6972 | Fax: 585-385-6004 | 803 Linden Ave. Rochester, NY 14625

Updated 1/17 | Datasheet Version 5.0 | ©2017 Vincent Associates

Key Features

- 25mm aperture
- Uni-stable operation
- **501A-S7** adapter included
- Slim, small form-factor
- **RoHS Compliant**
- Transfer time on opening:
9.0 milliseconds
- Total opening time:
12.0 milliseconds
- Configured for the **VCM-D1 Shutter Driver**

Product Options

CS25 2 3 4 5 6 - 7 - 8

Ex: CS25S3T0-EC-21

1 Shutter Series:

- **CS25**

2 Driver Compatibility:

- **S:** Use with VCM-D1 (Std.)
- **E:** Use with D880C or VED24

3 Housing:

- **1:** Un-Housed
- **3:** #3 Housing

4 Blade Coating: ¹

- **T:** Low Energy (Teflon[®])
- **ZM:** High Energy (AlMgF₂) ²

5 Electronic Sync:

- **0:** Omitted
- **1:** Included

6 Connector:

- **L:** 18" flying leads (*Un-housed only*)
- Leave blank for 5-pin Switchcraft connector

7 Encapsulated Coil:

- **EC:** Included
- Leave blank if not required

8 Mount: (*#3 housing only*)

- **21:** Zeiss Axiovert
- **24:** Olympus BX/IX
- **27:** Nikon
- **105:** C-Mount (Male)
- **106:** C-Mount (Female)
- Leave blank if not required

¹ Other blade coating options may be available by special order.

² Input side only; Teflon[®] coating is on opposite side to protect shutter blade surface. Light source must be input to the reflective side only.

Shutter Timing

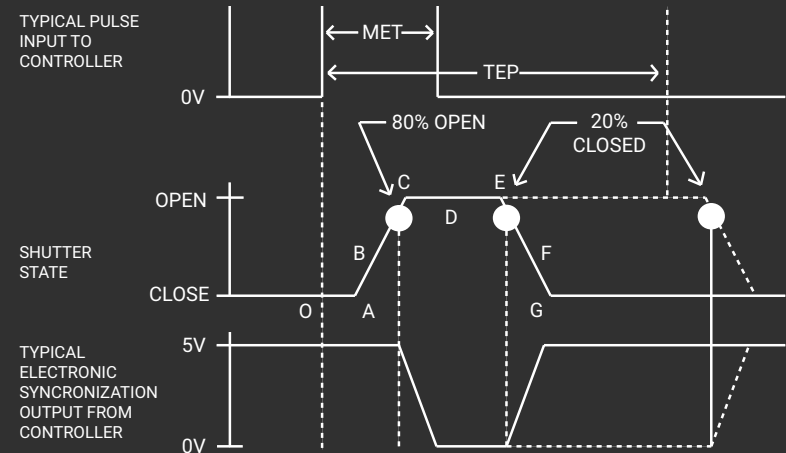

CS25 (w/ VCM-D1 driver and Teflon[®] coated blades) Time (msec.)

| Transition | Description | Time (msec.) |
|------------|---|--------------|
| O - A | Delay time on opening after current applied | 3.0 |
| A - C | Transfer time on opening | 9.0 |
| O - C | Total opening time | 12.0 |
| C - E | Min. dwell time with min. input pulse | 6.0 |
| B - F | Min. equivalent exp. time | 17.5 |
| E - G | Transfer time on closing | 14.0 |
| A - G | Total window time | 29.0 |
| MET | Min. exposure time | 15.0 |
| TEP | Typical exposure pulse | >15.0 |

Technical Specifications

| Coil Resistance | Voltage to Open | Hold Voltage (Nominal) ¹ |
|-----------------|-----------------|-------------------------------------|
| 12 Ω | +65 VDC | +5 VDC |

¹ Voltage level required across actuator coil when being held in the open position.

² (Continuous/Burst) Continuous frequency rating specified at shutter's minimum exposure pulse. Burst frequency rating specified for four (4) seconds maximum with one (1) minute minimum between bursts.

| Series | Weight (Unhoused) | Weight (Housed) | Operating Temp. | Max. Opening Bounce | Max. Closing Bounce | Max. Freq. of Operation ² | Number of Shutter Blades |
|--------|-------------------|-------------------|-----------------|---------------------|---------------------|--------------------------------------|--------------------------|
| CS25 | 1.28 oz (0.04 kg) | 3.16 oz (0.09 kg) | 0 - 80 °C | 15% | 5% | 5 Hz / 30 Hz | 5 |

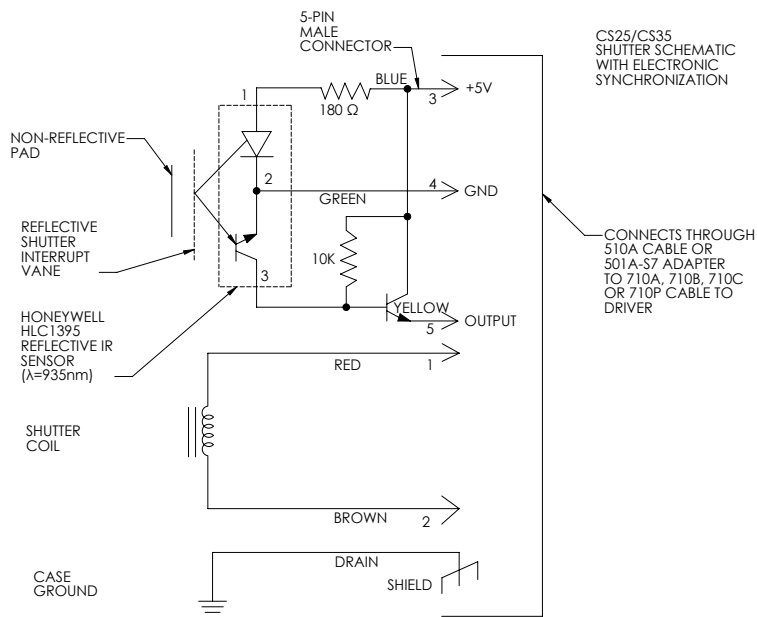

The electronic synchronization system provides a feedback signal (through the driver utilized) after the shutter transfers to the open state. The system incorporates an infrared emitting diode, an infrared sensitive detecting transistor, and an interrupting vane. The vane is attached to the shutter so as to block the light path between the emitter and detector in the closed position. When the shutter transfers to the 80% open position, the vane is removed from the infrared light path, allowing the emitter to switch the detector to the active state. For the CS25, this system uses a similar activation flag attached to the mechanism, which triggers a reflective emitter/detector device. **No connection to the designated synchronization pins when no electronic sync. is selected.**

Technical Drawings - Un-housed CS25

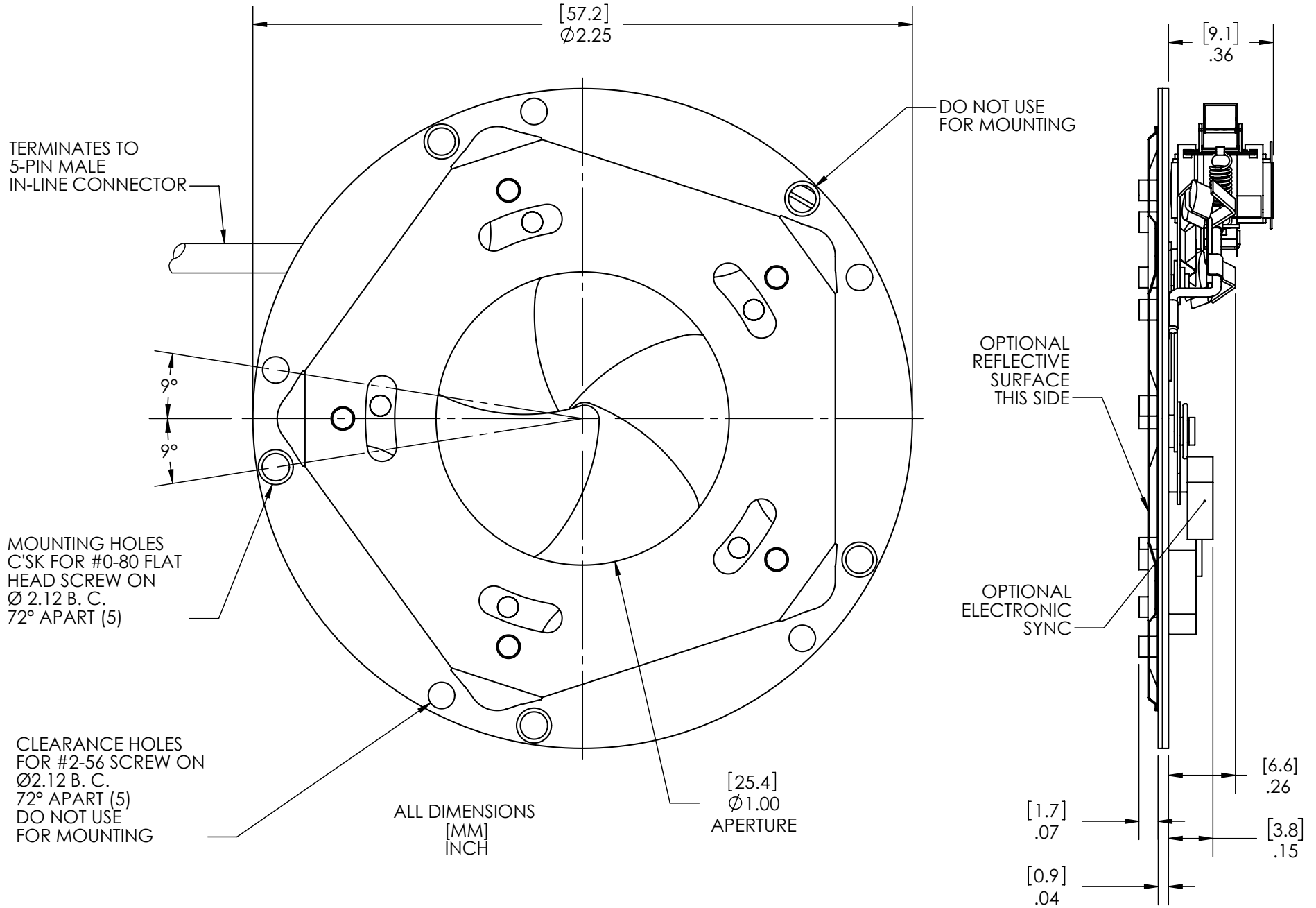

Technical Drawings - Housed CS25

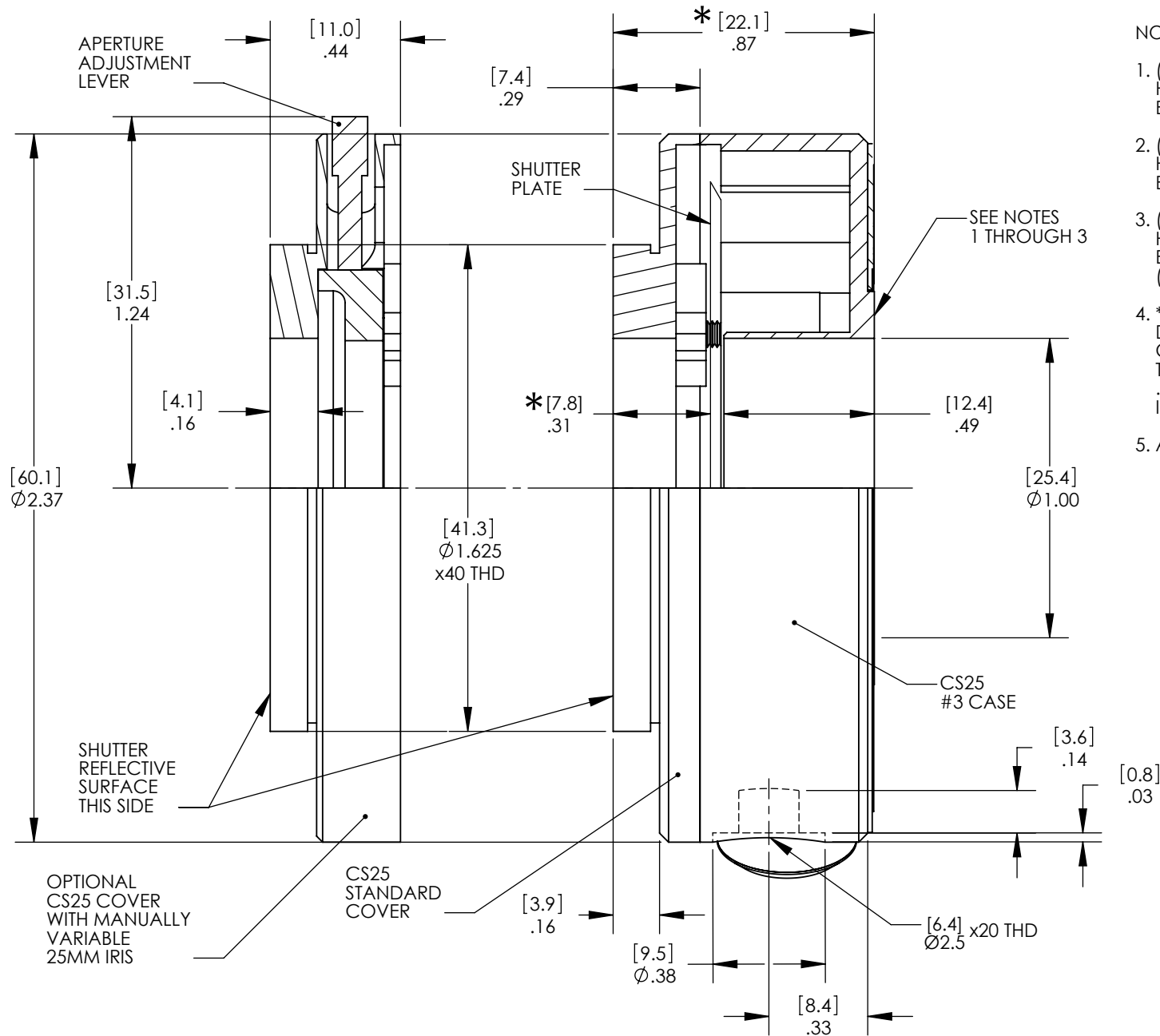

NOTES:

1. (3) #2-56 MOUNTING HOLES ON A Ø1.204 B. C. 120° APART.
2. (3) #2-56 MOUNTING HOLES ON A Ø1.578 B. C. 120° APART.
3. (4) #0-80 MOUNTING HOLES ON A Ø2.073 B. C. 90° APART. (UNDER NAME PLATE)
4. * - INDICATED DIMENSIONS WILL CHANGE FROM .87 TO 1.02 AND .31 TO .16, WHEN SELECTING IRIS COVER OPTION.
5. ALL DIMENSIONS MAX.
[MM]
INCH

Technical Drawings - CS25 Connector Layout

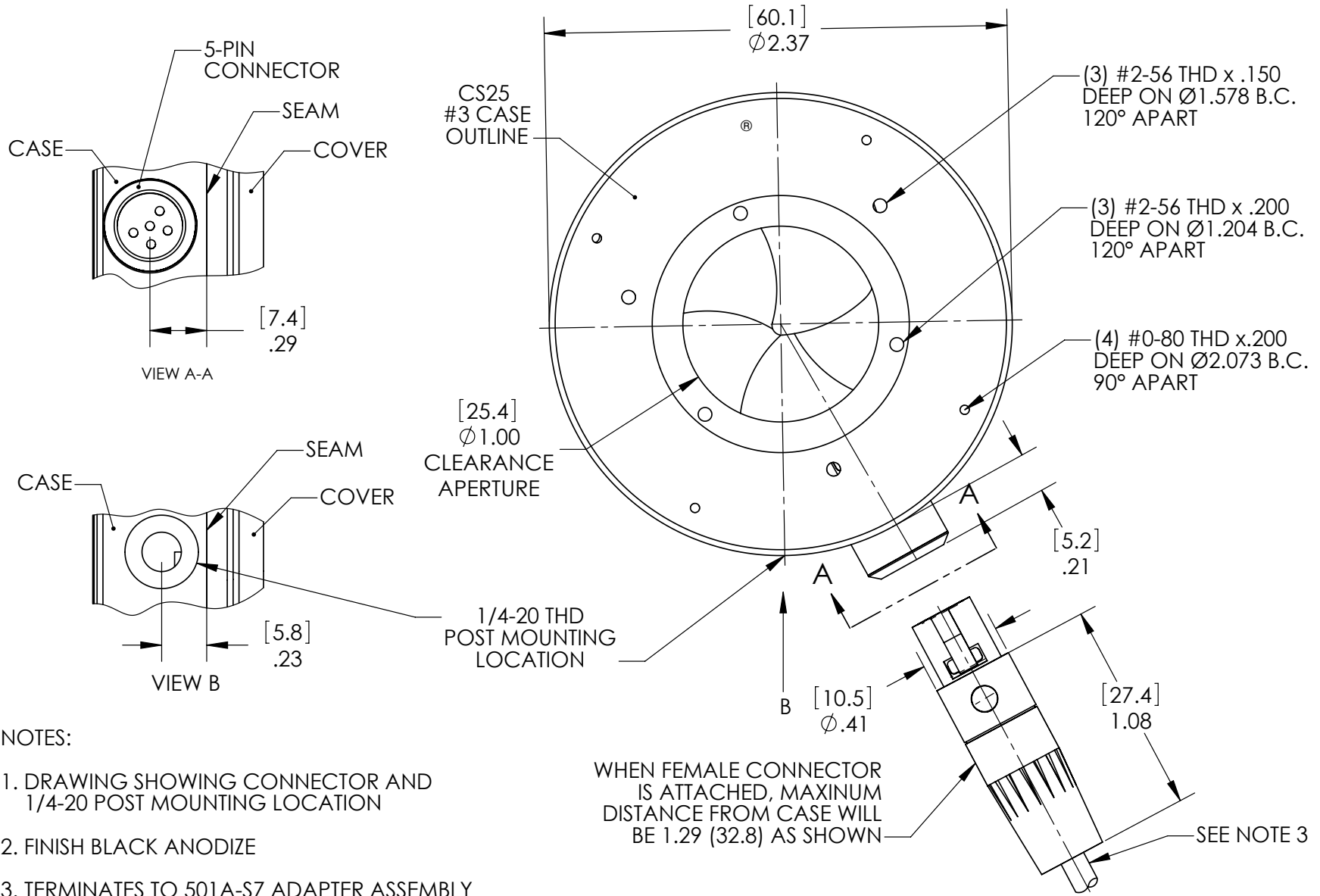

NOTES:

1. DRAWING SHOWING CONNECTOR AND 1/4-20 POST MOUNTING LOCATION
2. FINISH BLACK ANODIZE
3. TERMINATES TO 501A-S7 ADAPTER ASSEMBLY
4. ALL DIMENSIONS MAXIMUM:
[MM]
INCH

WHEN FEMALE CONNECTOR IS ATTACHED, MAXIMUM DISTANCE FROM CASE WILL BE 1.29 (32.8) AS SHOWN