

Uniblitz® NS65B

65mm Bi-Stable Optical Shutter



Overview

The Uniblitz NS65B is a 65mm-aperture bi-stable optical shutter utilizing our patented N-CAS® technology. The NS65B's simple design provides maximum clearance around the aperture, and a machined flat surface makes for its easy integration into telescopes, video cameras, etc. The NS65B has an overall diameter of 5.15 inches, and an electronic synchronization is available.

Bi-stable shutter devices, like the NS65B, require no power to hold the blades in either the open or closed state.

Need Support? Please [visit our website](#) or email us at info@uniblitz.com.

Tel: 585-385-5930 | Toll-Free: 800-828-6972 | Fax: 585-385-6004 | 803 Linden Ave. Rochester, NY 14625

Updated 5/16 | Datasheet Version 5.0 | ©2016 Vincent Associates

Key Features

- 65mm aperture
- Bi-stable operation
- Only two unique moving parts
- Slim, low-profile form-factor
- **RoHS Compliant**
- Transfer time on opening:
33.0 milliseconds
- Total opening time:
43.0 milliseconds
- Configured for the **VED24**
Shutter Driver

Product Options

NS65B **2** **3** **4** **5** - **6** - **7**

Ex: NS65B1T0L-EC-ED

1 Shutter Series:

- **NS65B**

2 Housing:

- **1**: Un-housed

3 Blade Coating: ¹

- **T**: Low Energy (Teflon®)
- **ZM**: High Energy (AlMgF2) ²

4 Electronic Sync:

- **0**: Omitted

5 Connector:

- **L**: 18" flying leads
- Leave blank for 5-pin Switchcraft® connector with 6" harness

6 Encapsulated Coil:

- **EC**: Included
- Leave blank if not required

¹ Other blade coating options may be available by special order.

² Input side only; Teflon® coating is on opposite side to protect shutter blade surface. Light source must be input to the reflective side only.

Shutter Timing

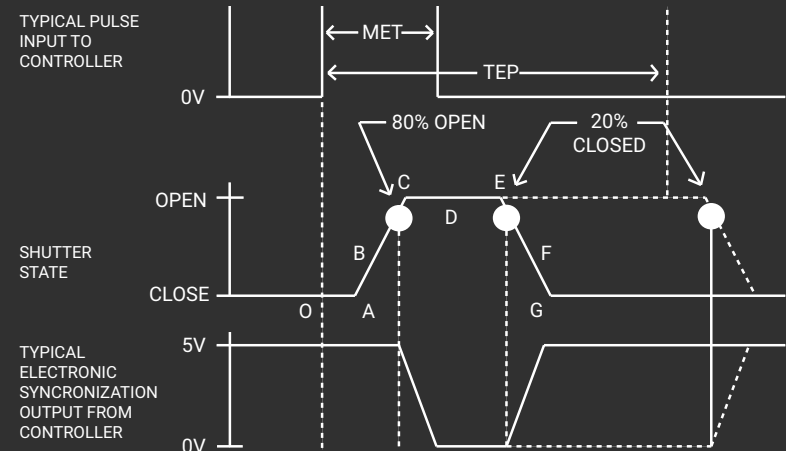

NS65B (w/ Uniblitz driver and Teflon® coated blades) Time (msec.)

O - A	Delay time on opening after current applied	10.0
A - C	Transfer time on opening	33.0
O - C	Total opening time	43.0
C - E	Min. dwell time with min. input pulse	15.0
B - F	Min. equivalent exp. time	47.0
D - E	Delay time on closing after current applied	12.0
E - G	Transfer time on closing	31.0
A - G	Total window time	79.0
MET	Min. exposure time	70.0
TEP	Typical exposure pulse	>70.0

Technical Specifications

Coil Resistance	Voltage to Open	Hold Voltage
12 Ω ¹	+36 VDC ²	N/A

¹ Two 24 Ω coils wired in parallel

² Peak voltage as provided by the **VED24 Driver**

³ (Continuous/Burst) Continuous frequency rating specified at shutter's minimum exposure pulse. Burst frequency rating specified for four (4) seconds maximum with one (1) minute minimum between bursts.

Series	Weight	Operating Temp.	Max. Opening Bounce	Max. Closing Bounce	Max. Freq. of Operation ³	Number of Shutter Blades
NS65B	4.94 oz (0.14 kg)	10 - 50 $^{\circ}\text{C}$	15%	5%	1 Hz / 3 Hz	6

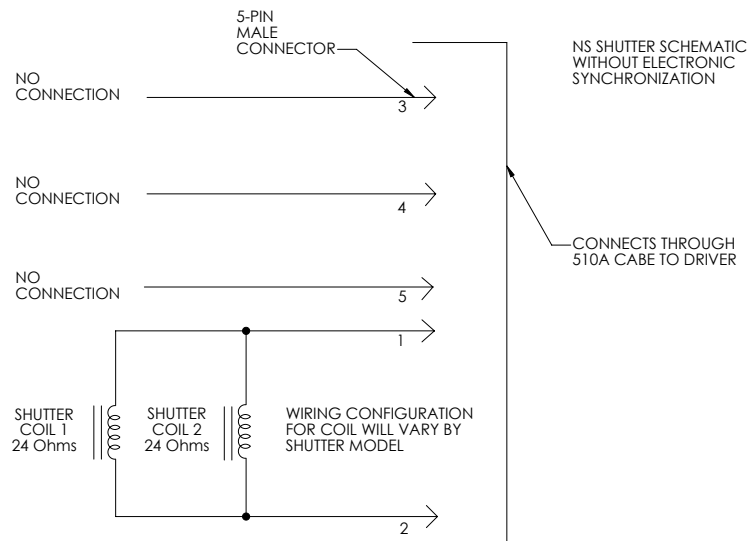

The schematic to the left illustrates the wiring for the NS65B. The schematic also shows the two 24 Ω coils wired in parallel to provide an equivalent resistance of 12 Ω .

Presently, the NS65B does not include a synchronization system as a standard option. Pins 3, 4, and 5 have no connections at this time. The synchronization feature may be available by special order if it is required for your application. Please **contact us** to discuss your request in further detail.

Technical Drawings - NS65B

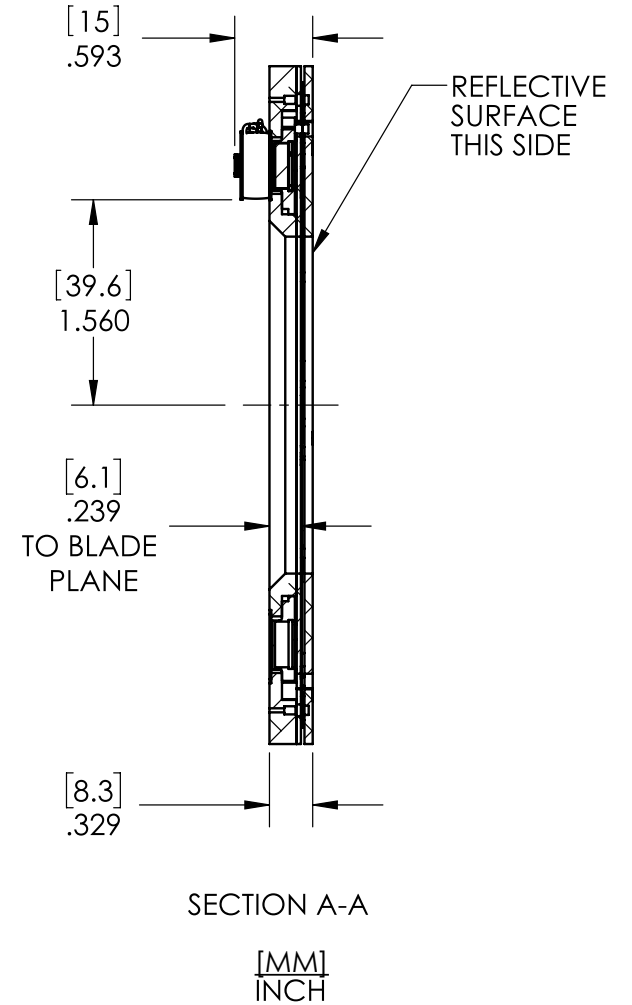
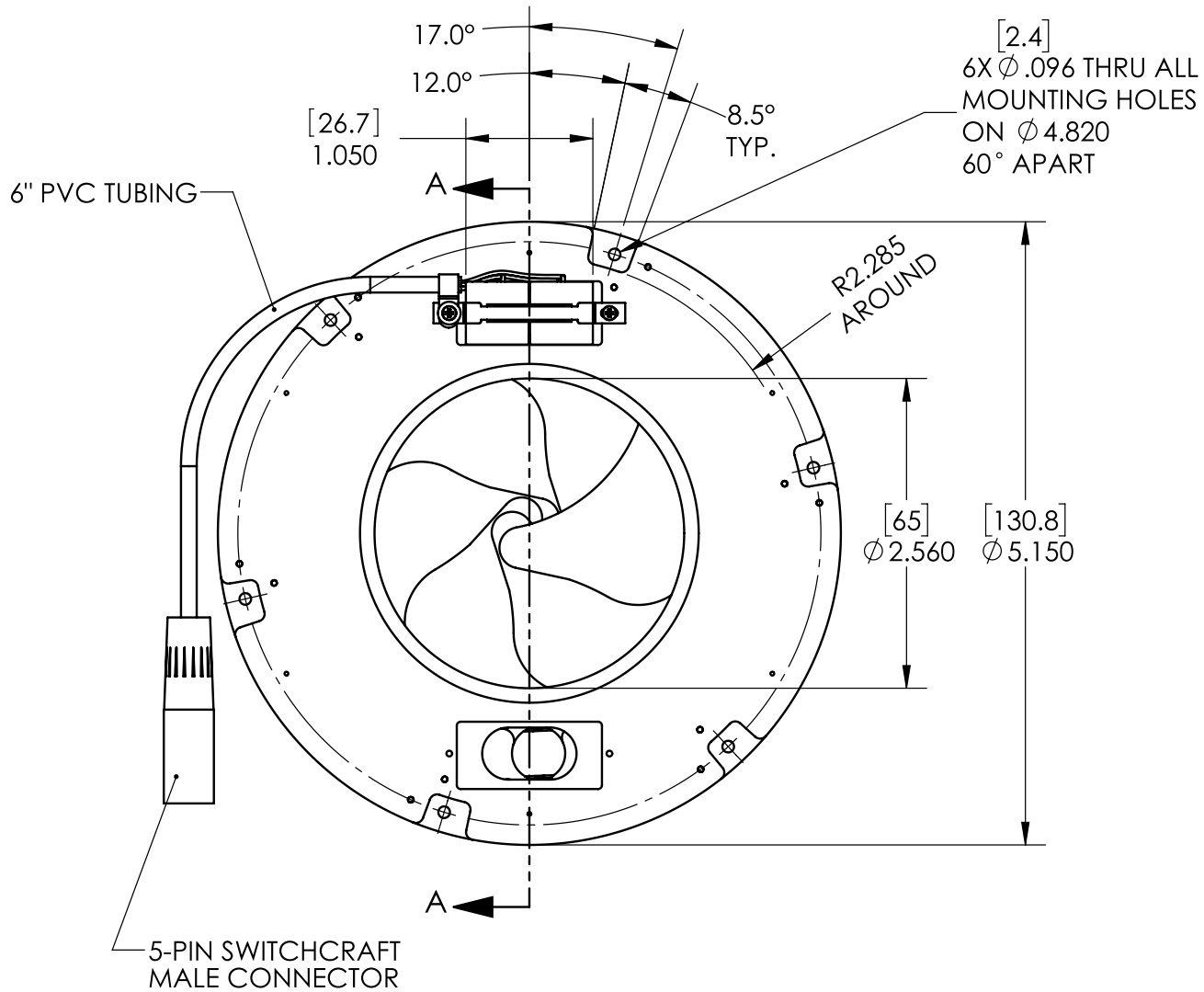

Technical Drawings - NS65B Mounting

6X 2-56 SCREWS
MOUNT IN
DIRECTION SHOWN

