

**Piezoelectric
bending actuators
Disk translators
("bimorphs")**

Piezoelectric tubes

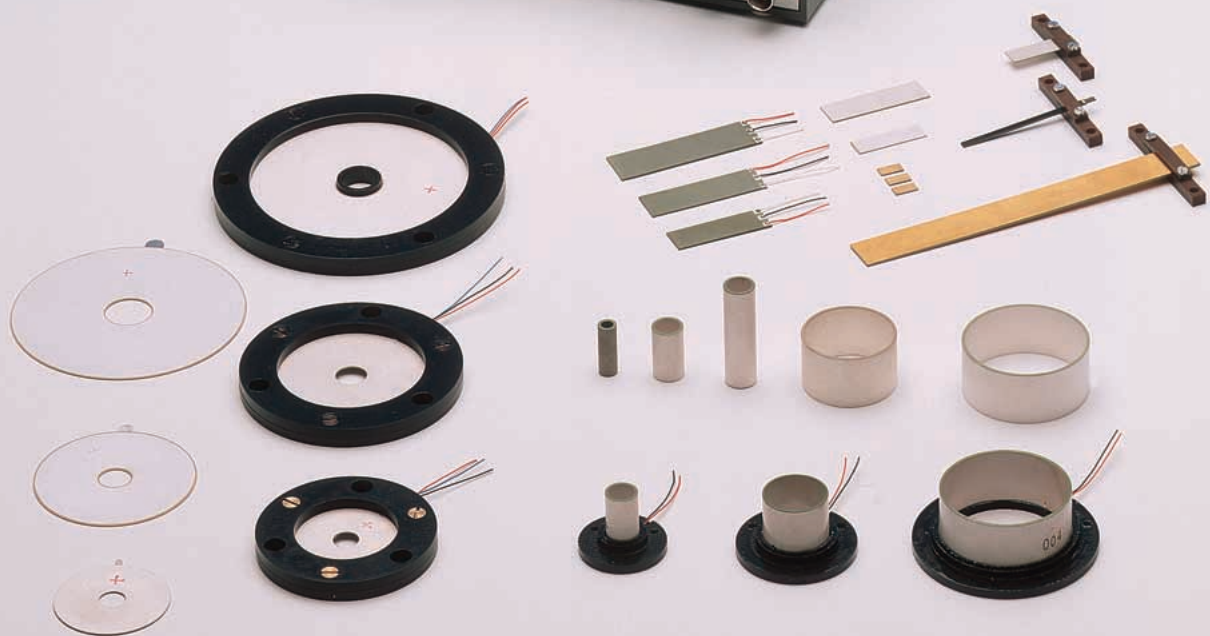

Contents:

Bending actuators

1.	Introduction	3
1.1.	Applications	3
1.2.	Basics: Polarization of PZT components	4
2.	Bender types (bimorphs)	5
2.1.	Serial benders	5
2.2.	Parallel benders	5
2.3.	Multilayer-benders	5
3.	Electrical operation of parallel bimorphs	6
3.1.	Standard operation	6
3.2.	Operation with “electrical prestress”	6
3.3.	“Unimorph-like” operation	6
4.	Actuating properties of PZT benders	7
4.1.	General	7
4.2.	Displacement	7
4.3.	Force generation, varying loads	7
5.	Mounting of strip- and disc-benders	8
5.1.	Strip-benders	8
5.2.	Disc-benders	8
5.3.	Electrical contacting	8
5.4.	Resonance frequencies	8
6.	Technical data	9
6.1.	Strip-benders	9
6.1.1.	Serial benders	9
6.1.2.	Parallel benders	9
6.1.3.	Low voltage multilayer benders (“multimorphs, polymorphs”)	9
6.2.	Disc-benders, disk-translators	10
6.2.1.	Disc-translators without centerbore ($d_1=0$)	10
6.2.2.	Disc-translators with centerbore	10
7.	Amplifier BMT 60	11
	Piezoelectric tubes	12

Bending piezoactuators

1. Introduction

1.1 Applications:

When a standard piezoceramic plate is electrically activated, it shows 2 modes of motion

1. a variation in thickness: when an electrical field of proper polarity is applied, the thickness increases. This effect is used with common piezo stack actuators.
2. a planar motion: This mode always accompanies effect 1, and leads to a planar contraction of the plate under above conditions.

This effect is used in **piezoceramic bending actuators (often designated as unimorphs, bimorphs)**

When the PZT-layer is joined to a proper substrate sheet (e. g. a thin metal plate), any electrical activation of the PZT plate leads to a planar movement of the plate relatively to the

substrate and induces thereby an internal mechanical stress resulting in a bending movement of the composite structure similar to a thermo-bimetal (Fig. 1).

This works with a single PZT layer e.g. on a thin metal plate ("unimorph"), but such a system shows strong variation with temperature. A symmetric arrangement, using 2 PZT layers ("bimorph"), which are counteracting with their planar contraction/expansion, is thermally stable and shows improved displacement/force generation.

Such bending structures are used as actuators, force sensors, acoustical generators (buzzers) etc.

PIEZOMECHANIK offers a wide range of bilayer or multi-layer PZT-benders in strip or disc geometry

PZT benders show

- **bigger travel (up to mm) than PZT stacks for comparable operating voltages.**
 - **simple structure**
 - **flat design**
 - **wide range of operation parameters (travel, force, stiffness, resonance frequency)**
- together with the PZT specific properties
- **short reaction time**
 - **vibrationfree electro-mechanical energy conversion**
 - **no magnetic field**

and open thereby a lot of interesting design solutions e.g. in

- **positioning equipments (video/audio heads)**
- **optical tuning/chopping**
- **electrical relais**
- **valve actuation**
- **fans**
- **micropumps**

When used for high resolution positioning tasks, the philosophy of the application of PZT-benders is similar to PZT stacks:

By combining the PZT actuator with a positioning sensor via a feedback control loop, a compensation for hysteresis, drift and varying load is obtained resulting in an ultimate positioning accuracy and stability.

Because the PZT effect is a dual effect, **bending elements** are successfully used as vibration and force **sensors** as well as small electrical **generators**.

1.2. Basics: Polarization of PZT components

To understand the different philosophies of bender designs and operating modes, it is necessary to look for some details of PZT material, especially polarization.

When you are buying a simple PZT plate or disc, you will find the electrical polarity indicated on the element, and it is stated, that voltage has to be applied with correct polarity. Nevertheless, it is possible to drive such elements to some extent with counterpolarity inverting thereby the direction of motion e.g. the thickness of the plate shrinks and vice versa the plate shows a planar expansion.

The very important point in this context is, that the acceptable **voltage range for this counteraction is much lower** than the voltage range in forward direction and this limits the travel range. The theoretical countervoltage limit is defined by the “coercitive field strength” and depends on the type of PZT ceramic. The application of too high countervoltages leads to depolarization or polarization reversal and thereby deactivate the component or change it property. Because depolarization is further supported by mechanical forces/stress and/or elevated temperatures, the acceptable countervoltages have to be held sufficiently low to avoid any risk of depoling under all conditions and **the stated limits of countervoltages have to be observed strictly.**

The coercitive field depends on the type of PZT material: “Piezoelectrically hard” PZT ceramic is more stable against depoling, but shows rather low actuating efficiency. “Piezoelectrically soft” PZT ceramic shows good actuating efficiency in forward direction, but easily changes polarization. For several technological reasons, “soft” PZT has to be used in multilayer low voltage actuators, manufactured by co-firing technology.

This detailed explanation is necessary to show the limitations of the simplest operating mode of conventional bending elements. It makes use of this voltage reversal to produce the counteraction between the two PZT layers. Such benders are therefore made from “semi-hard” or “hard” PZT ceramics. But there are a lot of advantages, when operating modes are used, which avoid countervoltages:

- no risk of desactivation of bender even under critical driving conditions (mechanical stress, temperature)
- higher mean electrical fields and thereby higher displacement rates
- full working range for “high efficiency” benders, made of “soft” PZT or electrostrictive ceramics.

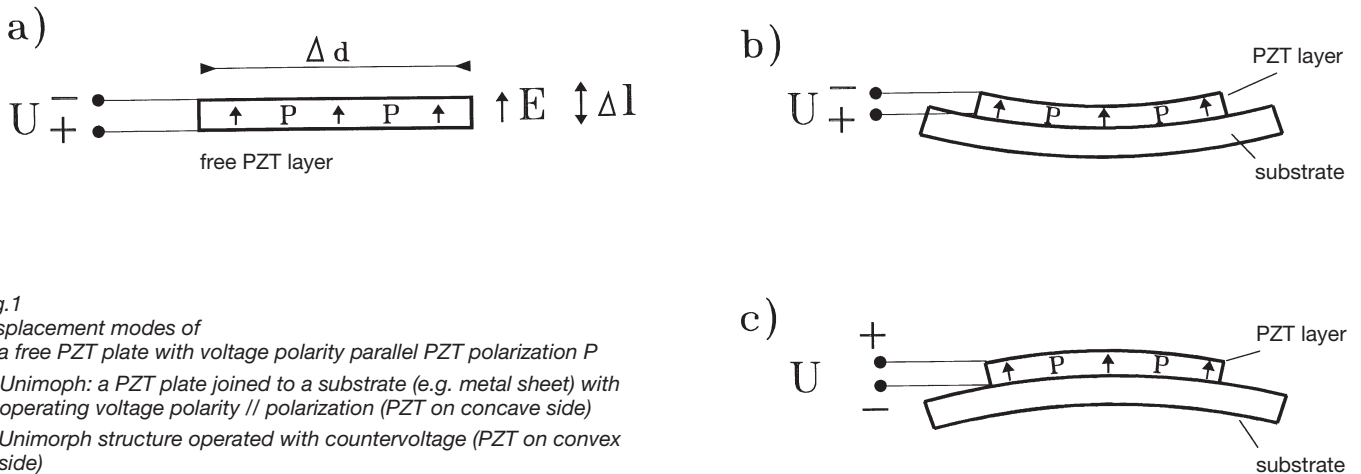

Fig.1
Displacement modes of
a) a free PZT plate with voltage polarity parallel PZT polarization P
b) Unimorph: a PZT plate joined to a substrate (e.g. metal sheet) with operating voltage polarity // polarization (PZT on concave side)
c) Unimorph structure operated with countervoltage (PZT on convex side)

2. Bender types (bimorphs)

2.1. Serial benders

Common serial benders consist of 2 thin PZT plates, discs or strips with opposing polarizations. They are glued together by a proper adhesive, showing only 2 accessible (surface) electrodes for operation.

An application of a distinct voltage leads to a contraction of the PZT layer, where E and P are parallel and expansion of the PZT layer where E and P are antiparallel.

Serial bending elements show a bilateral movement starting from zero (middle position), when a bipolar voltage is applied. Because of the risk of depoling, the specified limits of driving voltages have to be observed strictly.

With this type of bender, the electrical capacitances of the involved PZT layers are operated serially.

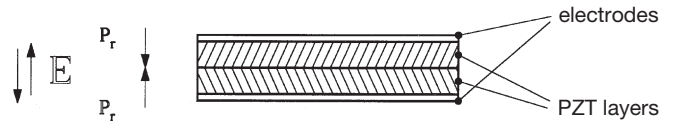

Fig. 2
Serial bender arrangement with antiparallel polarization in PZT layers, bilateral motion for bipolar driving voltage

2.2. Parallel benders

For the applicator, the easiest way to distinguish a standard parallel bimorph from a serial element is, that 3 electrodes have to be connected (2 surface electrodes and 1 middle electrode).

The middle electrode can be a metal sheet as neutral fiber improving the mechanical properties of the bender or a thin metalization layer on the PZT. The electrical capacitances of the PZT layers are then connected parallel.

The standard 3-electrode design of parallel-bimorphs offers more alternatives for driving modes than the serial types.

The PZT polarization P of conventional parallel bimorphs is mostly parallel in the PZT layers as shown in fig. 3, but there exist some applications with antiparallel polarization. (e.g. see 3.3.)

The individual contacting of each PZT layer offers the choice, not only to produce a bending movement, but also a transla-

tional component: the tip of a strip bender moves axially, when the 2 PZT layers are activated for parallel motion. By superimposing axial and bending motion, you get a bi-dimensional actuator, which may be useful for some scanning microscope technologies.

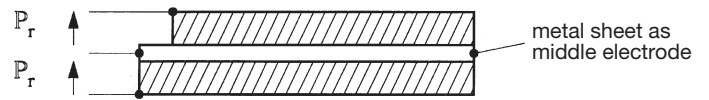

Fig. 3
Schematic of a parallel bender structure, 2 PZT layers (e.g. parallel polarization) 3 contact electrodes

2.3. Multilayer benders

They behave like parallel benders (3 electrical contacts), but are built up from more than 2 PZT layers (polymorphs, multimorphs). The layers are joined together by high temperature sintering (not by an adhesive) and have therefore better

mechanical properties. From technological and performance reasons, such multilayers are made from "soft" PZT. The polarization of the PZT-layers can be easily switched and be adapted to the different driving modes.

3. Electrical operation of parallel bimorphs

3.1. Standard operation

This is the simplest operation of parallel-benders and most frequently used. The surface electrodes are usually set to ground. For a bilateral motion, a bipolar signal is applied to the middle-electrode. It is obvious, that one of the PZT layers is operated with counterpolarity.

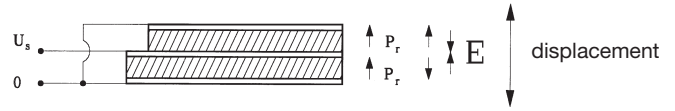

Fig. 4
Operation of a parallel bimorph with outer electrodes grounded and bipolar signal to middle electrode.

3.2 Operation with “electrical prestress”

The main difference to 3.1. is a distinct fix voltage difference U_i , applied to the 2 outer electrodes with voltage polarity according PZT polarization. For an open middle electrode, this leads to a contraction of both lamellae and therefore an unchanged middle position of the bimorph.

A bilateral bending movement is achieved, when a voltage U_s is applied now to the middle electrode, varying in the range $0 \leq U_s \leq U_i$. For $U_s = U_i/2$, the bender ist in middle position.

Hereby the PZT layers are operated without countervoltage improving thereby their properties (see sec. 1.2.).

Piezomechanik has designed a range of special 3-pole amplifiers for this operating mode (see chapter 7 “bimorph-driver” BMT 60 or brochure “amplifiers”).

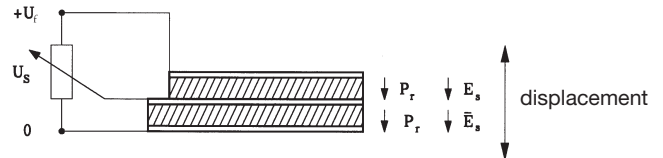

Fig. 5
Parallel-bender with “electrical prestress” operation

3.3. “Unimorph-like” operation

The purpose of this driving mode is again to avoid counter-voltages within “soft” PZT benders. In this case, only one layer of the bimorph is activated (by a voltage polarity according PZT’s polarization). The other layer remains inactive (e.g. disconnected). This procedure results only in a unilateral deflection. For getting a deflection in the other direction, the electronic supply has to be switched to the formerly inactive layer etc.

When only one PZT layer is used for actuation, the other, inactive layer can be used as displacement/force sensor.

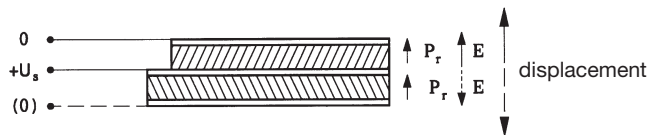

Fig. 6
“Unimorph-like” operation of a parallel-bender, notice antiparallel polarization under stated driving conditions for a bilateral motion.

4. Actuating properties of PZT benders

4.1. General

The bending effect of a PZT bimorph uses a mechanical magnification mechanism, transforming the small planar movement of a PZT layer to a much higher bending travel. Rather high magnification factors can be achieved. The simple physical consequence is an equivalently reduction in force generation, stiffness and resonance frequency compared to unbended planar mode or to a PZT stack. Similar to PZT stacks, benders show the typical ferroelectric properties of PZT ceramic like hysteresis, drift and creep. Some of these effects are pronounced because of the high

4.2. Displacement

Fig. 7 shows the bilateral motion of typical bending structures starting with the first cycle at zero position and the hysteric motion after some periods. The bender is operated by bipolar voltage according 3.1. For operating mode with electrical prestress (3.2.), the displacement curve has to be recalibrated for a voltage range with 0V and U_{max} as reversal points and $U_s = U_{max}/2$ as middle position. The max. displacements for conventional benders stated in the data sheet are valid for constant load conditions.

4.3. Force generation, varying loads

The common displacement diagrams for PZT actuators are valid for constant load conditions. A lot of applications show varying load conditions e.g. when the actuators are used for force generation. Due to the limited stiffness of actuators any variation of load acts back on the element. Therefore, the resulting max. displacement depends on the force generation (change of load force!) produced by the actuator as shown in fig. 8. The blocking force B is the maximum force, which can be produced by a distinct actuator. In this case, no displacement occurs for full driving voltage: infinite stiff clamping of actuator. Or in other words: the blocking force is needed to press back an actuator from maximum amplitude to its zero-position.

internal mechanical shear stress acting on the ceramic and adhesive joint of the layers. Some stabilization against these effects can be achieved by operation modes avoiding countervoltages (see sec. 1.2.). A complete compensation for these effects can be done by position feedback control in a similar way as with stacktype actuators.

Notice: The mechanical properties of bending actuators depend to some extent on the clamping/mounting conditions. The specified technical data are therefore approximatively.

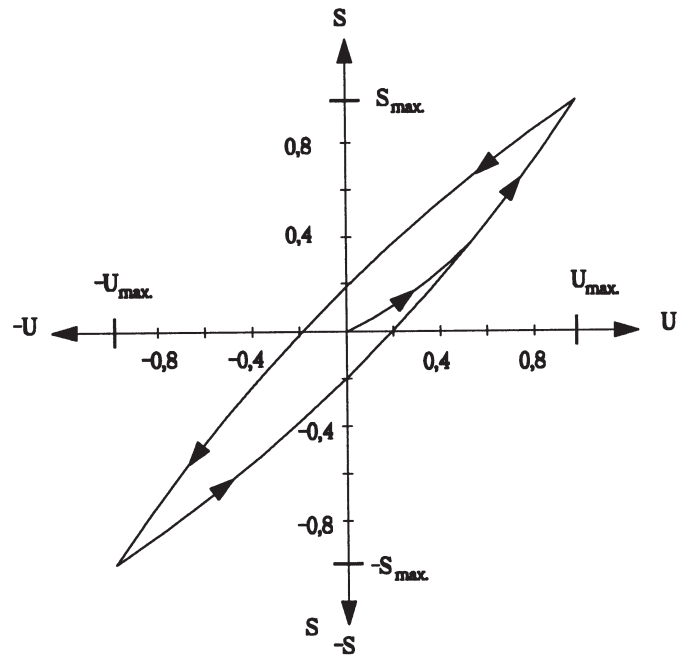

Fig. 7
Displacement characteristic of bimorph benders (either serial or parallel) for bipolar operating voltage.

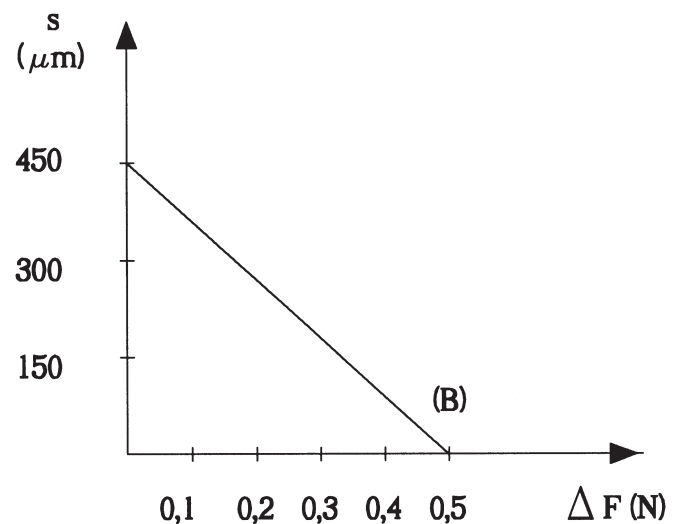

Fig. 8
Force/displacement diagram for varying load/force conditions.
 F = change of load force/generated force s displacement
 B = blocking force (max. generated force)

5. Mounting of strip- and disc-benders

Mechanical and electrical aspects

Benders can be made in a great variety of geometries, cut from a PZT bilayer or multilayer-structure.

The following remarks for the two basic geometries (strip-type and disc-type) should demonstrate some fundamental aspects of mounting of benders.

5.1. Strip-benders

One side fix mounted, other end moving freely:

For this mounting, the max. displacement of a strip-bender is achieved and the specified data for displacement, stiffness and resonance refer to this situation. The displacement depend on the free moving length of the strip. Usually approx. 5–10% of bender's total length are provided for mounting purposes. Mounting can be done by clamping or by using adhesives like epoxies, cyano-acrylates etc.

Notice: this bending action is not purely translatory, but shows also a small tilt of a component attached fix to strip's tip.

Notice: PZT-benders are fragile ceramic elements. When onside mounted benders are operated under resonance conditions with a deflection exceeding remarkably the maximum static displacement, accidental cracking of the element may occur due to mechanical overstress. This can be prevented by mechanical stops, limiting the maximum displacement.

2-point support

A pure translational movement is achieved by a strip-bender, when it is mounted on both sides near the ends.

In this case, the mid-elongation is 1/4 of the onside free moving arrangement. Vice versa the force/generation (blocking force) are increased by a factor of 4.

Attention has to be paid to the mounting conditions of the bender: it should not hinder some tilt/rotation of the ceramic layer at the support points, otherwise unwanted clamping reduces bender's efficiency.

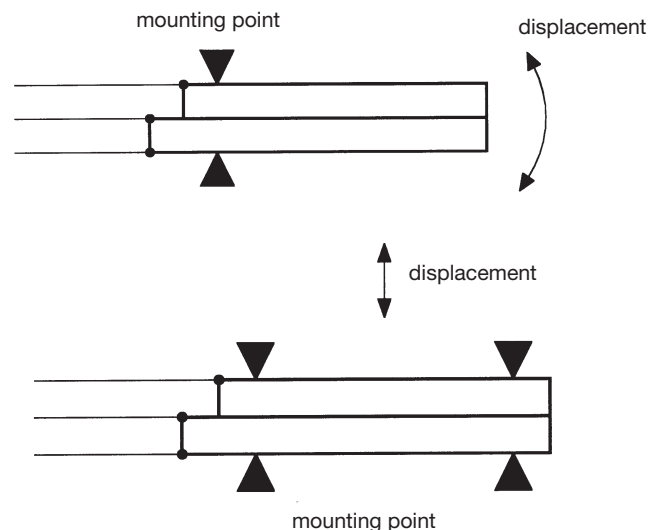

Fig. 9
Operating conditions for a strip-bender
a) one side fix, one end free
b) two ends fix

5.2. Disc-benders

Disc-translators are fixed at their circumferences and center's motion is used for actuating purposes. The displacement is purely translatory similar to the 2-point support situation with strip benders.

Mounting of disc benders at its circumference needs some flexibility at the contactline to avoid clamping effects as described above for the 2-side mounting of a strip-bender.

5.3. Electrical contacting

Conventional bilayer structures (serial and parallel bimorphs) show in most cases surface electrodes, which are sometimes connected to the supplyvoltage line of the signal generator. In these cases, the mounting of the elements has to provide electrical insulation. The operating voltages of benders can be rather high, therefore accidental touching has to be prevented.

Electrical contacting of benders is done by soldering, electrically conductive adhesives or metalspringcontacts. Soldering: heating of bender's electrode has to be done by short tipping (1–2 seconds) with a fine tip soldering iron (temperature approx. 250°C). Too long treatment with soldertin will dissolve the electrode metal coating.

The low voltage multilayer benders BM/ML have insulating ceramic surfaces and are provided with 3 pigtails (see fig.11).

5.4. Resonance frequencies

Resonance frequencies PZT bender arrangements depend not only on the mechanical properties of the bender, but also on supporting arrangement (e.g. 1-point, 2-point), free moving length, stiffness of mounting mechanism and mass load.

6. Technical Data

6.1. Strip-benders

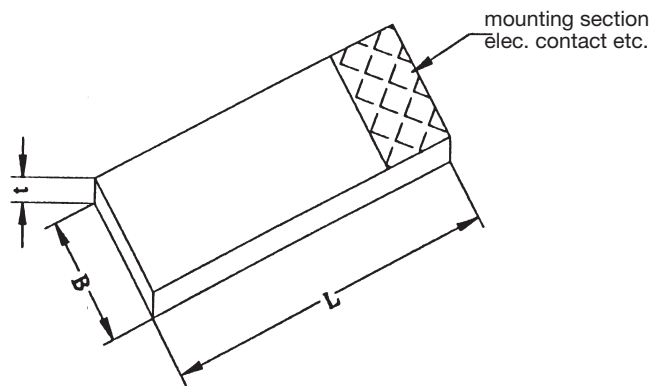

Fig. 10
Dimensions of strip-benders

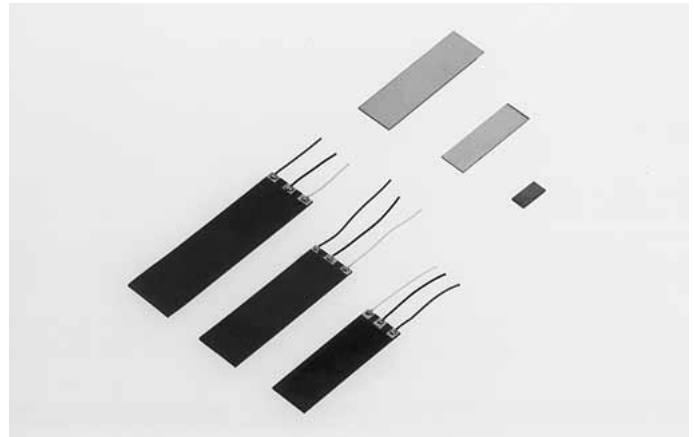

Fig. 11
Different types of strip-benders (Low voltage multilayer types with pig tails)

6.1.1 Serial benders

conventional bilayer types, adhesive type, surface electrodes, data valid for one-side fix, one side freely moving, free moving length approx. 90% of total length, bipolar (standard) operation

Typ	dimensions (mm)	voltage range (V)	el. capacitance (nF)	max. displacement (μm)	blocking force (N)	Resonance-frequency (Hz)
BM 300/08/010	8 x 4 x 0.6	± 300	1	± 10	ca. 0.05	5000

6.1.2. Parallel benders

conventional bilayer design, adhesive type; M: with middle layer metal sheet; "hard" PZT benders, parallel polarization in both layers

Typ	dimensions (mm)	voltage range (V)	el. capacitance (nF)	max. displacement (μm)	blocking force (N)	Resonance-frequency (Hz)
BM 70/25/200 M	25 x 7.5 x 0.4	± 70	20	± 200	0.15	300
BM 120/36/350	36 x 11 x 0.6	± 120	25	± 350	0.25	20

6.1.3 Low voltage multilayer benders ("multimorphs, polymorphs")

co-fired configuration (no adhesive)

For use with amplifier BMT 60

Type	dimensions (mm)	voltage range U_p (V)	el. capacitance (nF)	max. displacement (μm)	blocking force (N)	Resonance-frequency (Hz)
BM/ML 60/33/150	33 x 11 x 0.8	60	700	± 150	0,3	400
BM/ML 60/40/300	40 x 12 x 1	60	1300	± 300	0,3	250
BM/ML 60/50/450	50 x 14 x 1	60	2500	± 450	0,5	200

6.2. Disk-benders, disk-translators

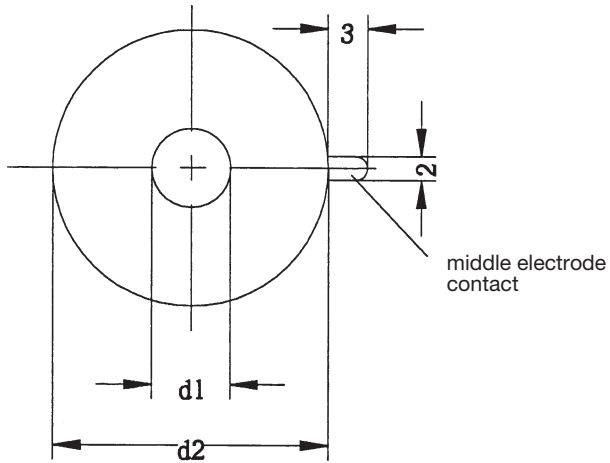

Fig. 12
Dimensions of circular benders

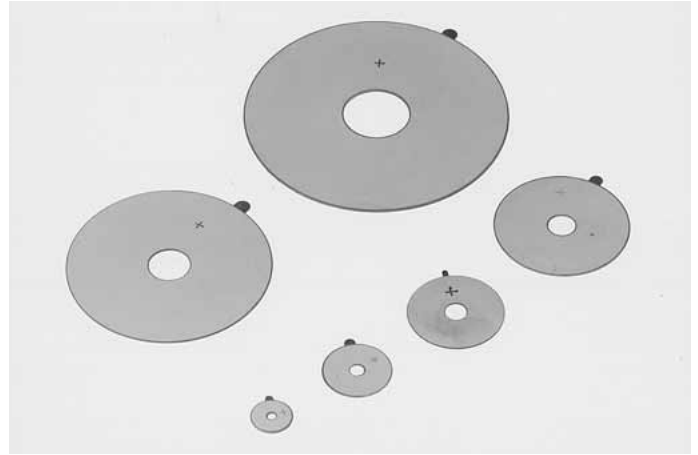

Fig. 13
Different types of disc translators with centerbore

General design: parallel types with middle metal sheet (M)
conventional bilayer arrangement; surface electrodes; "hard" PZT

Data valid for mounting by clamping at complete circumference, approx. 1 mm from edge

6.2.1. Disc-translators without centerbore ($d_1=0$)

type	dimensions $d_2 \times t$ (mm)	voltage ranges (V)	el. capacitance (nF)	max. center displacement (μm)	blocking force (N)	resonance frequency (kHz)
CBM 100/15/010 M	15 x 0.6	± 100	15	± 10	3	20
CBM 100/25/030 M	25 x 0.6	± 100	40	± 30	3	15
CBM 100/35/070 M	35 x 0.6	± 100	80	± 70	3	6.5

6.2.2. Disc-translators with centerbore

type	dimensions $d_2 \times d_1 \times t$ (mm)	voltage ranges (V)	el. capacitance (nF)	max. center displacement (μm)	blocking force (N)	resonance frequency (kHz)
CBM 100/ 15- 3/010 M	15 x 3 x 0.6	± 100	15	± 10	3	20
CBM 100/ 25- 5/030 M	25 x 5 x 0.6	± 100	40	± 30	3	15
CBM 100/ 35- 5/070 M	35 x 5 x 0.6	± 100	80	± 70	3	6.5
CBM 100/ 50-10/120 M	50 x 10 x 0.6	± 100	190	± 120	3	5
CBM 100/ 75-15/250 M	75 x 15 x 0.6	± 100	330	± 250	3	3
CBM 200/ 75-15/170 M	75 x 15 x 1.3	± 200	190	± 170	20	4.5
CBM 200/100-25/280 M	100 x 25 x 1.3	± 200	300	± 280	20	3

7. Amplifier BMT 60 for low voltage multilayer PZT benders

The BMT 60 3-pole amplifier has been designed to drive large capacitance, low voltage PZT benders (e.g. series BM/ML) with maximum bilateral displacement over a wide frequency range up to their mechanical resonances. The BMT 60 amplifier drives low voltage benders in the electrically prestressed mode and provide the necessary voltage levels. Any risk of depoling with deterioration of the excellent properties of the multilayer benders is thereby prevented.



Fig. 14
3-pole amplifier BMT 60

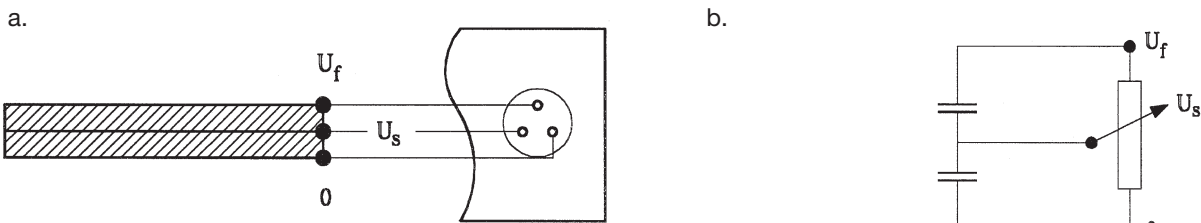

Fig. 15
a) connecting scheme for amplifier BMT 60 with multilayer benders
b) electric circuitry equiv. a

Technical data:

Input:

Signal range: +/- 5V (up to +/-15 V with attenuation, see below)
Resistance: approx. 100 kOhms
Connector: BNC

Output:

Voltages (3-pole):
Supply voltages: Ground (0 V)
 $U_f = +60$ V (fix)
 U_s : with 0 V U_s/U_f
Control voltage:

Max. current: 280 mA
Noise: 20 mV
Connector: 3-pole
(a corresponding plug with 1 m /3wire cable is supplied with the amplifier)

Control elements:

Potentiometer "Amplitude": for attenuating/adapting signals exceeding +/-5 V
Potentiometer "Offset": for manually setting a DC-output voltage level of U_s within the full working range.
This DC-level is superimposed to any signal supplied to the external signal.

Monitor: for checking the dynamic output signal U_s (versus ground) by an oszilloscope, reduction factor of signal 1:100, connector BNC
Display: 3-digit LCD
Dimensions: height 68 mm x width 165 mm x depth 210 mm
Weight: approx. 1.4 kg.

3-pole Bimorph amplifiers for voltage ranges up to 430 V are described in brochure "amplifiers"

Piezoelectric tubes

Piezoelectric tubes are monolithic ceramic elements and are metalized on the inner and outer surfaces. They can be used as actuators based on the d31 effect, resulting in

- a contraction of tubes length
- a contraction of the diameter of the tube (voltage polarity according PZT polarization)

Piezoceramic tubes are successfully used
to modulate the optical pathlength of wound up fibers
to shift mirrors within laser resonators
in scanning tunnel microscopy, AFM etc.
as fluid pumps (piezo ink jet printing)
for clamping mechanisms

Due to the purely monolithic ceramic, piezoelectric tubes can be operated under exotic conditions, e.g. ultrahigh vacuum, because of the lack of outgassing materials. Outbaking even with high temperatures is acceptable. The thermal depolarization of the PZT requires only a repolarization of the ceramic by applying 500 V in a first operating cycle. (By this procedure, the polarization even can be reversed compared to the original situation).

Piezomechanik offers a range of standard tubes made of soft PZT showing optimum actuating efficiency. Due to the highly sensitive material, the wallthickness of the tubes can be held rather thick (1 mm) to get good mechanical properties, high stiffnesses and resonance frequencies at acceptable driving voltages of up to 1000 V. A countervoltage up to approx. 200 V can be applied reversing now the motion of the elements to elongation instead of contraction, increasing thereby the total displacement range.

PZT tube
 inner/outer
 surfaces
 metalized

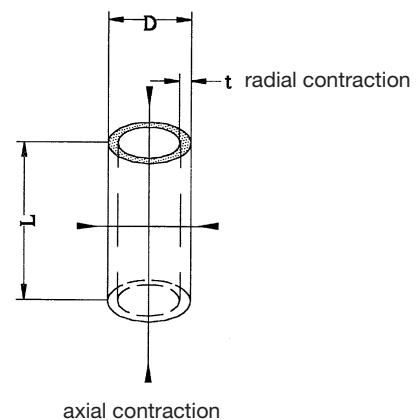

Fig. 16
 schematic and dimensions of PZT tubes showing the used operating modes axial/radial contraction

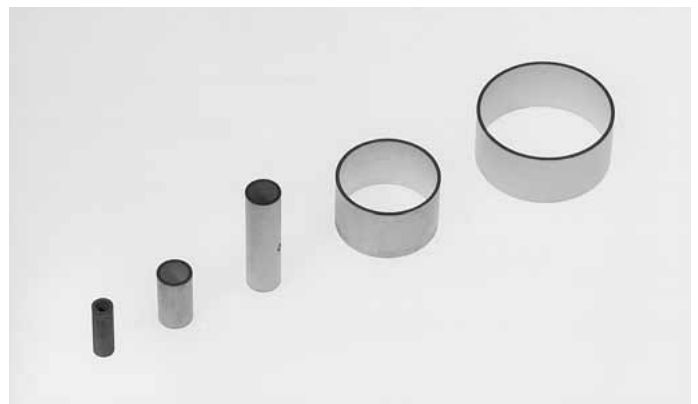

Fig. 17
 PZT tubes

Technical data:

Dimensions D x L x t (mm)	max. voltages U _{ap} /U _p (V)	el. capacitance (nF)	axial/diameter contraction* (µm)	resonance frequencies axially/radially (kHz)
6 x 18 x 1	-200/1000	15	8/ 2	80/75
10 x 18 x 1	-200/1000	27	8/ 3	80/65
10 x 36 x 1	-200/1000	55	16/ 3	40/65
20 x 18 x 1	-200/1000	55	8/ 6	80/40
30 x 18 x 1	-200/1000	85	8/ 9	80/30
40 x 18 x 1	-200/1000	110	8/13	80/22
74 x 20 x 4	+/-1000	20	2/ 5	80/13

*for voltage 0V to 1000 V

Electrode material: silver

Electrical contacting: as described für PZT benders in chapter 5.3

Piezomechanik · Dr. Lutz Pickelmann GmbH

Berg-am-Laim-Str. 64 · D-81673 München · Tel. XX 49/89/4 3155 83 · Fax XX 49/89/4 31 64 12

e-mail: info@piezomechanik.com · http://www.piezomechanik.com

